

## Waste identification and water utilization in the thread dyeing industry: An improvement strategy for long-term development

Nafisa Anzum Sristi<sup>1\*</sup>, Dr. Md. Ahsan Akhtar Hasin<sup>2</sup>

<sup>1</sup> Industrial and Production Engineering Department, Bangladesh University of Engineering and Technology, Dhaka- 1000, BANGLADESH

<sup>2</sup> Industrial and Production Engineering Department, Bangladesh University of Engineering and Technology, Dhaka- 1000, BANGLADESH

### ABSTRACT

Fierce competition in the textile sector forces one to make a production system more efficient and increase productivity by reducing total throughput time using the Lean manufacturing system. These two objectives can be achieved through Value Stream Mapping (VSM) and process modifications. Water usage is the textile industry's major environmental concern, but little research has been done on how to effectively manage water at the process level by identifying the crucial variables impacting the dyeing water consumption rate. This research targets these objectives in a Textile Dyeing company in Gazipur. Bangladesh's textile thread dyeing industry has a substantial impact on the national economy. Dyeing can be utilized at several phases of the textile-making process. Color is a crucial aspect of the appeal, regardless of how excellent a fabric's construction is. By reducing wastes that are identified at various stages of dyeing thread, the entire process can become more effective and efficient. Utilizing water wisely in the thread dyeing industry may result in a large decrease in water use, ensuring environmental sustainability. This research has been conducted at a reputed sewing thread manufacturing plant to explore the possibility of minimizing water use in the thread dyeing process without hampering the fabric quality and to identify any potential waste generated during the entire process. Non-value-adding activities have been identified for removal, some processes have been streamlined and some processes have been modified. Value stream mapping (VSM), a lean method that uses a flowchart to describe each stage in the production process, was applied to the 34-kilogram batch (the batch that is run the most) to find waste, shorten process cycle times, and implement process improvement. It is possible to gain a broad grasp of what is happening in the production system from this VSM, as opposed to what ought to or might occur. This helps to focus on the few most important reasons for the seven categories of waste it generates and eliminates. The "Radio Frequency Drying" and "Winding" procedures are identified as potential areas for improvement in this VSM, as their inventory and lead time are quite high. According to evaluations of the thread dyeing processing data gathered, there are a variety of variables that affect water consumption, including capacity utilization, product mix, shade depth, First Time Right (FTR), machine wash, and the adoption of new technologies or processes. These changes have a significant impact on productivity improvement.

Keywords: Process improvement, Waste identification, Dyeing, Value Stream Mapping (VSM).

### 1. Introduction

The textile industry is one of the largest in the world. The textile sector generates employment opportunities for those with little or no formal education, which is essential for reducing poverty in nations like Bangladesh and boosting GDP [1]. The biggest environmental concern in the textile industry is the amount of water and the chemical load it carries. Water is used extensively in the textile industry's dyeing sector. Throughout the entire production process, water is needed to clean raw materials and for many different steps. It was found that the bleaching procedure uses almost two-fifths of the water while dyeing uses a fifth. The majority of dyeing plants have been established on river-sides in Bangladesh, which has resulted in the degradation of the water environment, and this has put a great deal of pressure on Bangladesh's textile industry over the past few years due to increased pollution [2,3].

An essential element for the survival of mankind is water. Due to the excessive use of subsurface water, the water level decreases day by day. As a result, underground water is extensively used in the textile

industry. It's time to consider "how to ensure subsurface water is used properly." In Dhaka, groundwater sources provide 79 percent of the city's water supply, while surface water sources provide the remaining 21 percent. By 2030, Bangladesh's industrial water consumption is anticipated to double in terms of direct water withdrawals [4-6].

Despite making a significant economic contribution, Bangladesh's textile industry harms the environment, primarily through the contamination of water resources. In Bangladesh's industrial sector, a standardized system that takes sustainability and efficiency into account when accounting for water is lacking. Since a growing number of textile companies rely heavily on groundwater, there is an urgent need for effective water management at the process level as well as for groundwater conservation to ensure sustainable manufacturing practices.

To remain competitive in the textile industry, productivity and waste reduction are two of the most important factors, along with quality, worker efficiency, and work environment. Now is the time to focus on this

\* Corresponding author. Tel.: +88-01914377280  
E-mail addresses: sristi094@gmail.com

issue to reduce not only lead time but also manufacturing costs, which will be followed by waste reduction.

So, waste management has become increasingly important in the textile industry. Appropriate production planning and control can easily reduce waste in the textile industry, increasing the industry's profitability. To reduce waste, lean manufacturing systems and value stream mapping are very efficient and effective [7].

Waste management is a serious problem in a manufacturing company. Waste is anything that does not benefit the process in any way. Eliminating waste is one of the best methods to boost profitability. To reduce waste, one must first comprehend what waste is and where it is located in the factory.

Although the products from each factory vary, the usual wastes produced in a production environment are very similar. Taiichi Ohno, a former Toyota executive, identified seven types of waste after years of work to eliminate it. These wastes are as follows: overproduction waste; waiting time waste; transportation waste; useless and excess inventories waste; waste in the manufacturing process; unnecessary motion waste; and scrap and defects waste [8]. A longer waiting period will result in a longer lead time for production, which will delay delivery, raise production costs, disrupt production schedules, and so on [9]. Sutharsan et al. [10] studied the implementation effect of a lean tool, Value Stream Mapping (VSM), in the manufacturing industry to identify the non-value-adding steps in each operation.

According to the findings of the literature review, effective water management at the process level, as well as groundwater conservation, are critical to ensuring sustainable manufacturing practices. Furthermore, waste management has become increasingly important in the textile industry. In the textile industry, proper production planning and control can easily reduce waste, resulting in higher profitability. For this purpose, value stream mapping can be extremely beneficial.

The current study aims to improve productivity and make the production system of the thread dyeing industry more efficient by reducing total throughput time and inventory. The goal of this research is to identify wastes and their associated causes using the VSM technique and to propose any improvement strategies. This study also focuses on the factors affecting the utilization of water in the thread dyeing industry.

## 2. Process Study

This study was carried out in a reputed thread dyeing plant in Bangladesh for one month. Dyeing is the most value-adding process in this plant. In total 68 machines are used. Among them, 40 are sample machines and 28 are bulk production machines. The maximum capacity of a dyeing machine is 350 kg. The minimum capacity is 350 grams. The total design capacity of the dyeing floor is 22 tons per day.

Two tanks are used for dyeing. The main tank and prepare tank. 60% water is used in prepare tank. 40% water is added after that to the main tank. Preheated water is brought to the Prepare tank. Dyes and chemicals are then added to this water. After mixing them well, water is pushed to the main tank where the dyeing operation takes place. The dyeing machine is loaded with grey yarn from the carrier. Male-female package connections are made by loading the yarns so that they are in close contact with each other. Otherwise, when high pressure is given in the machine, the pressure can leak through loose contact and the yarns will have un-level dyeing.

Dyeing is a High-Temperature High Pressure (HTHP) method. Under 6 bar pressure, the temperature in the dyeing machine steadily increases (2-3 degrees Celsius per minute) up to 130 degrees Celsius. Air pressure is controlled by machine control. Water is continuously pushed and sucked through the pipes in an in-out process inside the machine. This is necessary for the distribution of dyes throughout the whole pack. After 2-5 hours repetition of this process dyeing is completed. Different products take a different amount of time for dyeing.

Hydro Extractor is a machine for drying wet products. Centrifugal force is applied in the yarns which take out 90% of the water. The products are rotated at 1400 rpm speed. Generally, no problem occurs due to the loading of different shades of colors together in the Hydro Extractor. But very light and white shades are not loaded with dark or too bright shades, as extracted color from dark shades can cause damage to the lighter shades. There are four hydro extractors on the dyeing floor. Out of these four, three machines are operational and one is kept as a backup for maintenance or breakage downtime. The capacity of the three operational machines is 15 tons/day, 15 tons/day, and 7.5 tons/day. The capacity of these three machines is 96, 48, and 24 packs. QC tests have been used at different points throughout the process. It starts with yarn testing and ends with finished goods inspection and customer complaints.

After the raw yarn has been dyed, the hydro extractions have been completed, and the sample has been QC approved, it is moved to the finishing section. The finishing process begins with two Radio Frequency (R/F) dryers on the dye-house area's bottom floor. The R/F drier completely dries the thread. The principle is similar to that of a microwave oven, and radiofrequency is used. The vibration of the molecules increases as the frequency rises, and the temperature rises as well. The residual liquids in the threads are vaporized at this temperature. The items are loaded onto a belt conveyor, which travels through the dryer at speeds of 9–10 m/h in one machine and roughly 17 m/h in the other.

The threads are wound in cones for industrial application from the dyed packaging. The yield is the number of cones that can be produced from a single package. The winding machine is set to run at a maximum pace of 1200 meters per minute. The splicer is used to connect any threads that break during this

operation. The total design capacity of the winding machines is 130000 cones/day (i.e. 18.6 tons/day).

After a batch of cones has been wound, the batch card is scanned and a nose sticker is printed from the system for each cone. The nose sticker on each cone is applied by hand. Cones that have been poly-packed are then placed in cartons. The system prints F/G notes and barcode stickers for each carton, which are then manually applied to the cartons.

### 3. Methodology

Currently, the Bangladesh textile dyeing industry does not have any public data on the amount of water used to dye one kilogram of yarn and the amount of production loss. Therefore, site visits have produced the majority of the data needed to carry out the study.

#### 3.1 Value Stream Mapping (VSM)

Value Stream Mapping is a method for illustrating the flow of resources and information used to produce a product from suppliers to consumers. Waste in the flow of materials and information that impacts lead time, space, and cost can be found via value stream mapping. This method is also helpful for recognizing time that adds value and time that doesn't while monitoring materials and data throughout various procedures [11, 12].

Value stream maps are classified into three types.

1. Current
2. Ideal
3. Future

A current state map outlines the high-level processes that must be followed from the time a customer orders or requests service until it is delivered to the customer. It depicts what is occurring right now, not what ought to or might occur. Before attempting to develop maps of an ideal or future condition, it is crucial to fully comprehend the current state [13].

#### 3.2 Water Consumption Measures

Data for this study was gathered through observation. The basic data for the study came from the dye house, winding department, and finishing department. The water flow meter was incorporated with the dyeing machine. This meter can calculate each fill of water. Finally, determine how much water is required for the entire dyeing process. The formula used to calculate water usage per kilogram of yarn was as follows [14]:

Water consumption per Kg yarn = (Total amount of water needed for this batch in liter) ÷ (Batch weight in Kg)

### 4. Analysis and Discussion

#### 4.1 Process Improvement using Value Stream Mapping (VSM)

The current state of VSM is depicted in Fig.1, displaying the various activities of the process steps as well as their durations. Value-added, non-value-added,

and unnecessary non-value-added activities are identified.

From Fig.1, it is found that the Total Lead Time is 3781 min and the Total Value Added Time is 329 min. The "Radio Frequency Drying" and "Winding" procedures have been identified as potential areas for improvement in this VSM, owing to their high inventory and lead time.

Before attempting to build ideal or future state maps, it is critical to fully comprehend the current situation to focus on the few most important reasons for the seven categories of waste it generates and eliminates.

Here are a few suggestions for a future stage implementation strategy's tools:

1. As the dyeing floor (22 tons per day) has a higher capacity than the R/F drying (15 tons per day) and winding (18.6 tons per day) departments, capacity balancing between the various departments is required. Inventory results from capacity imbalances between different departments.
2. Departments with large inventories can reduce waste in the manufacturing process by implementing a "pull" flow of materials.
3. One operator manages both the loading and unloading of packs in the R/F (radio frequency) drying process. It is required to assign two operators to perform loading and unloading separately because it loses time and lengthens cycle times.
4. Preventive maintenance can be employed.
5. Implement the Total Quality Management (TQM) system.

By implementing the suggested tools and techniques, the organization might be able to reduce non-value-added time and thus increase efficiency.

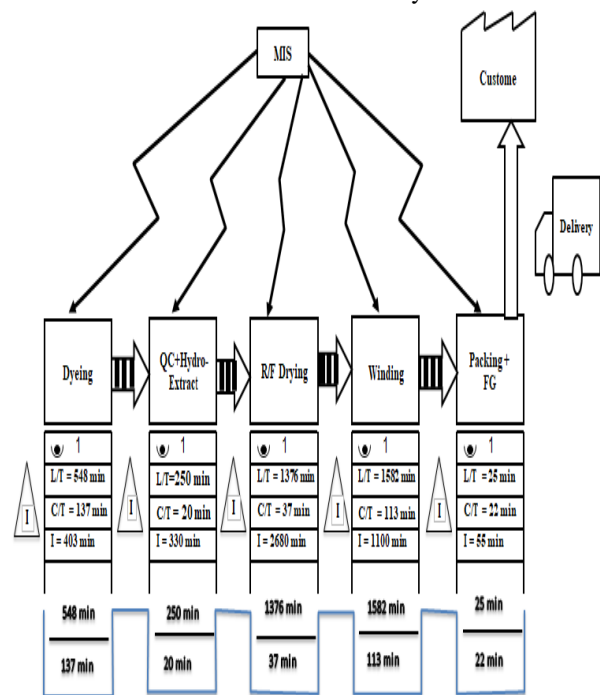
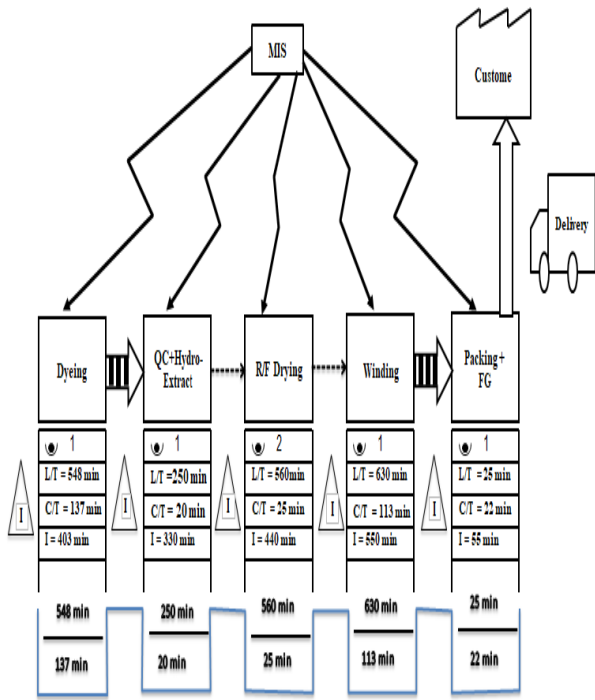

Fig.1 Current State VSM for Production Process

Fig.2 depicts the proposed VSM, which shows the various activities of the process steps as well as their durations, along with some suggestions.

According to Fig.2, the Total Lead Time is 2013 minutes and the Total Value Added Time is 317 minutes, both of which are less than the current state VSM. Inventory and lead times in the "Radio Frequency Drying" and "Winding" procedures will be improved further by balancing capacity across departments.



**Fig.2 Proposed VSM for Production Process**

#### 4.2 Determination of water consumption and its influencing factors

The collected yarn dyeing processing data shown in Table 1 reveals that water consumption quantity varies; there isn't a fixed amount of water consumed for dyeing.

**Table 1** Actual data of Water Consumption.

Obs. No.	Depth of shade	Yarn weight (kg)	Total Fill amount	Water consumption (liter/kg)
1	Dark	13.26	476	35.90
2	Very Dark	22	870	39.55
3	Dark	24	900	37.50
4	Light	27	560	20.74
5	Very Light	48	920	19.17
6	Medium	17	528	31.06
7	Medium	22	556	25.27
8	Medium	32	720	22.50
9	Medium	14	370	26.43
10	Dark	24	780	32.50
11	Dark	32	1020	31.88

12	Dark	16	520	32.5
13	Light	24	480	20.00
14	Dark	22	737	33.50
15	Light	19	353.4	18.50

So, it is important to identify which factors affect the dyeing water consumption rate. An analysis based on the collected yarn dyeing processing data has been employed. It is found that capacity utilization, product mix, shade depth, First Time Right (FTR), machine wash, and the adoption of new technologies or processes affect water consumption.

The depth of the shade is very important for utilizing water usage. So, the machines must be sequenced according to the depth of shade.

Very light → Light → Light medium → Medium → Medium-dark → Dark → Very dark

When dyeing a light shade of color after a dark shade, a large amount of water is wasted because the entire machine must be washed. However, because one machine wash takes almost as long as the yarn dye process and wastes a lot of water, it's more efficient to limit machine washing to a minimum by considering the depth of shade.

#### 5. Conclusion

Textile is the fastest-growing sector in Bangladesh and the textile dyeing process revolves around water. The excessive use of underground water for textile dyeing, which causes the water layer to gradually recede, is alarming for Bangladesh. Utilizing water wisely in the thread dyeing industry may result in a large decrease in water use, ensuring environmental sustainability. It is critical to determine which factors influence the dyeing water consumption rate. This study's contribution area enables effective water utilization in thread dyeing and productivity improvement. It was found that water consumption is influenced by capacity utilization, product mix, shade depth, First Time Right (FTR), machine wash, and the adoption of new technologies or processes. The study concludes that inventory is a big issue for the business under study, impacting the company's productivity and lengthening the lead time for production. This issue is likely to exist in other textile industries in Bangladesh as well. It is critical to fully comprehend the current situation to identify potential areas for improvement before attempting to build ideal or future state maps. In this study, "Radio Frequency Drying" and "Winding" procedures have been identified as potential areas for improvement in the current state of VSM, owing to their high inventory and lead time. Including suggestions such as pull flow and increasing the number of operators in the proposed VSM can considerably decrease total lead time and inventory. Further improvements can be made possible by balancing capacity across different departments. Therefore, other related industries can use the VSM method and proposed suggestions to add value to their processes by reducing inventory.

Finally, future studies may employ quantitative and mixed-method techniques to examine potential material waste scenarios while taking into account the whole product life cycle, from design to disposal.

## 6. References

- [1] J. Keane and D. W. Te Velde, The role of textile and clothing industries in growth and development strategies, Overseas Development Institute, May 2008.
- [2] Dutta, P., Sufian, M.A., Sheen, S.M. and Chowdhury, S., Economical and Sustainable Practices towards Knit-Dyeing Plant Utilizing Enzymes, International Journal of Emerging Trends in Engineering Research, vol. 8(8), pp. 4067 – 4078, 2020.
- [3] Shibly MAH, Tamanna TA, Efficient water utilization in knit dyeing factory of Bangladesh, J Textile Eng Fashion Technol, vol.6(3), pp.71-75, 2020.
- [4] Chakraborty, R. and Ahmad, F., Economical use of water in cotton knit dyeing industries of Bangladesh, Journal of Cleaner Production, 340, p.130825, 2022.
- [5] PwC presentation, Consolidation and analysis of information on Water Resources Management in Bangladesh, 18 October 2014.
- [6] Hossain, L., Sarker, S.K. and Khan, M.S., Evaluation of present and future wastewater impacts of textile dyeing industries in Bangladesh. Environmental Development, 26, pp.23-33, 2018.
- [7] Silva S.K. N., Applicability of Value Stream Mapping (VSM) in the Apparel industry in Sri Lanka , International Journal of Lean Thinking, vol.3, Issue 1, 2012.
- [8] Liker, Jeffery K., The Toyota Way – 14 Management Principles from the World’s Greatest Manufacturer, Page 27, McGraw Hill, 2004.
- [9] Akter, M.M.K., Haq, U.N., Islam, M.M. and Uddin, M.A., Textile-apparel manufacturing and material waste management in the circular economy: A conceptual model to achieve sustainable development goal (SDG) 12 for Bangladesh. Cleaner Environmental Systems, 4, p.100070, 2022.
- [10] Sutharsan, S.M., Prasad, M.M., Vijay, S., Productivity enhancement and waste management through lean philosophy in Indian manufacturing industry, Materials Today Proceedings, 2020.
- [11] Basher, A and Hasin, M. A. A., Lean manufacturing awareness and its implementation status in the apparel industry in Bangladesh, International Journal of Lean Enterprise Research, Vol. 2, No. 3, pp. 202-216.2018.
- [12] Basher, A and Hasin, M. A. A., Lean implementation: The progress and the future challenges of apparel industry to achieve the manufacturing competitiveness, Journal of Mechanical Engineering, Vol. ME-48,pp. 30-36, Dec 2018.
- [13] Mohammad, Azim, Shibbir Ahmad, and Mohammad Iqbal, Identification of retention time & information delays applying value stream mapping technique in apparel manufacturing organization. In Proceedings of the 2015 International Conference on Operations Excellence and Service Engineering Orlando, Florida, USA, September, pp. 10-11. 2015.
- [14] Haque, M.S., Nahar, N. and Sayem, S.M., Industrial water management and sustainability: development of SIWP tool for textile industries of Bangladesh, Water Resources and Industry, 25, p.100145, 2021.