

Heat Transfer and Fluid Flow Analysis in a Corrugated Plate Heat Exchanger

Sukanto Biswas¹, Mohammad Ilias Inam¹, Prokash Chandra Roy^{1,*}

¹ Department of Mechanical Engineering, Khulna University of Engineering & Technology, Khulna-9203, BANGLADESH

ABSTRACT

The corrugated plate heat exchangers have some significant benefits over orthodox heat exchangers due to easy maintenance and assembly-disassembly capability. This type of heat exchanger usually focuses on improving geometry by increasing the surface area in a heat exchanger and the heat transfer rate from plate to fluid. It works in an efficient manner for both single-phase and two-phase flow. In this study, the performance of a modified corrugated plate heat exchanger was studied numerically using ANSYS- Fluent 20R1. A transient, pressure-based model was selected for the analysis. For the turbulence model, k- ω SST was chosen. A nanofluid, base fluid of water containing nanoparticles of a metallic oxide (Al_2O_3) was used to enhance thermal conductivity. A wide range was taken in account with regard to Reynolds numbers (1000-12000). The effects of nanofluid on Nusselt number and Heat transfer coefficient were studied for the volume fraction of 0.2-2. The temperature distribution at different volume fractions inside the heat exchanger was also studied. At the hot outlet, temperature increases; at the cold outlet, temperature decreases with the increase in Reynolds number. Although the heat transfer coefficient was increased with the increase of volume fraction of Al_2O_3 while the surface Nusselt number decreased with the increase of volume fraction. The lowest heat transfer coefficient was found to be 12605.46 W/m²K for volume fraction 0.2 and the highest heat transfer coefficient was found to be 13017.43 W/m²K for the volume fraction 2.0. On the other hand, for the surface Nusselt number, the maximum value was found to be 199.5 for volume fraction 0.2 and the minimum value was found to be 122.16 for volume fraction 2.0.

Keywords: Corrugated, Nanofluid, Nusselt number, Heat transfer coefficient, Reynolds number

1. Introduction

Efficient heat transfer is very important to save energy. Efficiency mostly depends on the fluid used and the surface area of the heat exchanger. Conventional liquids like water, oil, acetone, ethylene and glycol used in heat exchangers have low thermal conductivity. So, it hinders the high compactness and effectiveness of heat exchangers. Several techniques can be used to enhance heat transfer. Contaminating such traditional fluids with nanoscale solid particles is an innovative technic to increase their conductivity. This mixture is called nanofluid, which has rapidly progressed in research. A combination of metal or oxide nanoparticles, such as Al_2O_3 , TiO_2 , Cu, and CuO, dispersed in base fluids including water, ethylene glycol, and motor oil is referred to as a nanofluid. Numerous researchers have shown that the greater thermal conductivity of nanofluids above their base fluids is mostly caused by the higher thermal conductivity of metals than liquids. Conduction heat transfer is not the only improvement. Uses of nanofluid are seen in simple geometries like circular pipes, but actual thermal/fluid system like complex heat exchangers has not been reported in a decent number. In this study, CFD methods using ANSYS FLUENT software were used for computational analysis has been emphasized. At first, the fluid taken for CFD simulation was a base fluid (water) to verify data with experimental results. The simulation was done with base fluid and nanofluids of different concentrations for the same geometry configuration of the heat exchanger to investigate the performance of nanofluids. The surface of the plate also has a great impact on heat transfer. Here the main focus was to take a surface of corrugated fashion. Corrugated plate largely extends the surface area of the heat exchanger, thus increasing heat transfer. At first, water was taken for plane surface plate counter flow heat

exchanger and corrugated surface plate counter flow heat exchanger with different angles of corrugated fashion to visualize the effect on the fluid temperature difference. Afterward, the actual focus of the paper, nanofluid along with the corrugated surface plate, was taken for simulation to determine the heat transfer. For simple geometries like circular pipes, nanofluids have been studied. However, for complex heat exchangers, as in actual thermal/fluid systems, few reports have been published in regard to their performance. For the computational analysis, CFD methods have been used with ANSYS FLUENT. In the first step, water was taken as the working fluid for CFD analysis to compare the CFD results with experimental data for verification.

2. Literature Review

Amir et al.[1] with his CFD approach investigated the fluid flow and heat transfer of nanofluids in corrugated plate heat exchangers. In his study, he used Al_3O_2 as nanoparticles and did the whole simulated experiment in Ansys Fluent. Pantzali et al.[2] numerically and experimentally studied the nanofluid CuO-water Nanofluid and its base fluid, they came to an agreement that heat transfer was greatly enhanced with nanofluid and this enhancement is more effective at lower flow rates. Pantzali et al.[3] also carried out a similar type of research to investigate nanofluids' efficiency when used as coolants in a heat exchanger using a different type of PHE. Their measurement results showed that confirming the general trends reported in the literature, the addition of nanoparticles to the base fluid greatly affects the properties of the nanofluid. A numerical study was carried out by Santra et al.[4] to estimate the effects of carbon nanoparticles in water on the shear wall stress and Nusselt number. The estimation was done for laminar flow having

* Corresponding author. Tel.: +88-01864209896
E-mail addresses: roy1605060@stud.kuet.ac.bd

a Reynolds number less than 1500 and a volume concentration of nanoparticles below 5%. They found that the nanoparticles have very small effects on the fluid flow but have a significant effect on the heat transfer rate. Hwang et al.[5] studied heat transfer and pressure drop of Al_3O_2 -water nanofluids in a circular tube with an inner diameter of 1.812 mm for fully developed laminar flow under constant wall heat flux. Thermodynamic properties measured in the study were thermal conductivity, density, viscosity, and heat capacity and were compared with their previous correlations and included in their analysis. The friction factor and convective heat transfer coefficient were obtained for nanoparticles sizing the 30 nm at various fractions of volume ranging from 0.01% to 0.3%. Maiga et al.[6] performed a forced convection numerical analysis through a pipe uniformly heated using the nanofluid of water- Al_3O_2 and ethylene glycol- Al_3O_2 . After the experiment, they found that the latter nanofluid exhibits better heat transfer properties than the previous one. An experimental work was done with corrugated surface and nanofluids by Raheem et al.[7]. In this study, SiO_2 -water nanofluid and two different corrugated channels (semicircular and trapezoidal) were used. The trapezoidal channel performed better than the semicircular channel. Wongcharee et al.[8] carried out an experimental experiment using CuO -water nanofluid and a corrugated pipe assembled with the twisted pipe. They found that heat transfer rate increases with the increase in nano fluid concentration and with the decrease in the twisted ratio. Lazarevikj et al.[9] used a counterflow plate heat exchanger and water- Al_3O_2 nanofluid to perform a CFD analysis. The heat transfer characteristics were greater than only water as fluid. Moreover, the efficiency was 12-23% using different concentrations of nanofluid. He, Yurong, et al.[10] performed a numerical study using TiO_2 -water nanofluids on a laminar condition within a straight tube and examined the convective heat transfer characteristics. It shows a significant enhancement of heat transfer rate. Finally, they also verified the numerical data with experimental data. An experimental investigation by Sommers et al. [11] using Al_3O_2 -propanol nanofluid. They found that changes in viscosity were nonlinear. They did not find any significant improvement in heat transfer rate rather, it deteriorated compared to the baseline case. Saleh et al.[12] recently run an experimental study using a corrugated plate heat exchanger and Ni-water nanofluids. The overall heat transfer coefficient is elevated by almost 38% at a 6% volume fraction and Re 700. Nevertheless, the index ratio of performance declined due to an increase in viscosity, pumping power and friction factor. A recent experimental work was done by Hu, Qingxiang, et al. [13] with corrugated tubes in a heat exchanger. The working fluid was air-helium. Empirical relations with Re and geometric parameters were proposed for the Nu. Zaboli, Mohammad, et al.[14] did a numerical study for both a shell heat exchanger and a corrugated tube heat exchanger using different water-based nanofluids. Among these, CuO -water shows the best thermal performance. In this paper, primarily heat transfer properties were analyzed using a same chevron angle (60 degree), longer channel

length (200) mm and larger channel thickness (3 mm) than et al. A. Jokar [1]. Moreover, a larger channel thickness (62m) was considered necessary for large-scale analysis.

3. Methodology

3.1 Computational Model

Several solution models are used in ANSYS fluent for this type of experiment. Among them, k-epsilon, k-omega and k- ω SST are the most classic ones. The near-wall dumping functions of the k-epsilon model are unreliable in a variety of flows. This problem was solved with the k- ω SST, as near-wall dumping functions are not required in this model. But the k-omega solution model is sensitive to freestream values in the inlet is sensitive in model. So, the k- ω model was modified overcoming those issues by introducing k- ω SST solution model. The k- ω SST solution model is the most advanced turbulence model in ANSYS fluent. Fig.1 depicts the geometry and boundary conditions for the experiment. The inlets of the hot and cold fluids are kept at a constant temperature of 323K and 298K, respectively. Here, in this investigation, radiation heat transfer and conduction heat transfer with the atmosphere is not considered. Inlets of the fluids are taken as constant velocity inlets with a turbulence intensity of 5% with a hydraulic diameter of 0.087. Free convective heat transfer was considered for water only. In this study, Al_3O_2 nanoparticles with an average diameter of 2 nm were mixed with water as base fluid with different concentrations ranging 0.2%–2.0% volume fraction.

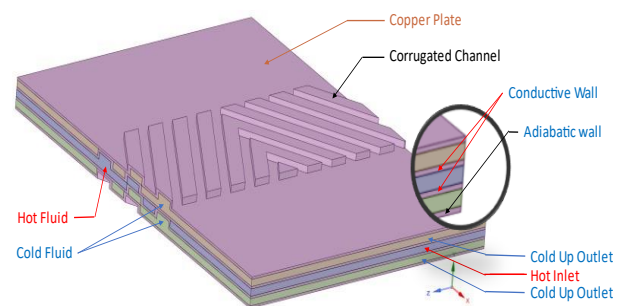

Fig.1 Geometry and boundary conditions

For more clarification to understand the geometry, the dimensions are also shown in Fig.2. All of the numerical analysis was performed using this geometry. In this investigation, four corrugated plates, making three channels for the water to flow through, have been taken. The dimension of a single plate is 200 mm in length, 134 mm in width and 1mm thick. Corrugation length is 80 mm in the plate with a chevron angle of 60 degrees. The total thickness of the assembled plates is 13mm, which makes a 3 mm channel for the water.

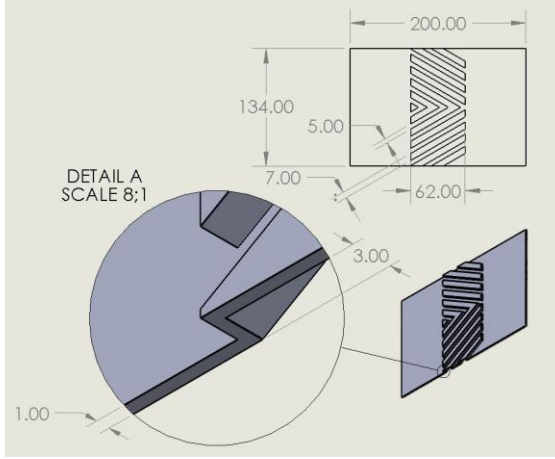

Fig.2 Dimensions of the geometry

3.2 Mathematical Model

Governing equations of conservation of mass, momentum and energy in steady-state conditions are as follows:

Conservation of mass:

$$\nabla \cdot (\rho V) = 0 \quad (1)$$

Conservation of momentum:

$$\nabla \cdot (\rho V V) = -\nabla P + \nabla \cdot \mu + \mu_t \nabla V + \nabla T \quad (2)$$

Conservation of energy:

$$\nabla \cdot \rho c_p V T = \nabla \cdot k + k_t (\nabla T) + \rho \epsilon \quad (3)$$

In this study for turbulence model, k- ω SST [15] was used.

Turbulent kinetic energy:

$$U_f \frac{\partial \rho k}{\partial x_j} = \tau_{ij} \frac{\partial u_i}{\partial x_j} - \beta^* k \rho \omega + \frac{\partial}{\partial x_j} \left[(\mu + \sigma_k \mu_t) \frac{\partial k}{\partial x_j} \right] \quad (4)$$

Specific dissipation rate:

$$U_j \frac{\partial \rho \omega}{\partial x_j} = \frac{\gamma}{v_t} \tau_{ij} \frac{\partial u_i}{\partial x_j} - \beta \rho \omega^2 + \frac{\partial}{\partial x_j} \left[(\mu + \sigma_\omega \mu_t) \frac{\partial \omega}{\partial x_j} \right] + 2(1 - F_1) \rho \sigma_{\omega 2} \frac{1}{\omega} \frac{\partial k}{\partial x_j} \frac{\partial \omega}{\partial x_j} \quad (5)$$

3.3 Validation

The model has been analyzed using Ansys Fluent 20R1. It has been validated with solutions obtained from two previously published research articles. For plain water, et al. A. Jokar found heat transfer rate of 2717 W, and we found 2736 W for the present work. For 1% volume fraction of nanoparticles, heat transfer rate of 2672 W was found, and in our work, heat transfer rate was 2689W.

3.4 Grid Independency Test

In order to increase the credibility of the study, a mesh independency test was run. For doing this, Nusselt Number (Nu) was taken on the vertical axis and cell number on the horizontal axis in Fig:1. We start by taking a cell number of 0.25 million. Then the cell number increased gradually. After the Nusselt number reached the value of 50 at the cell number of 8.5 lakh, no change in Nu was observed with the change in cell number. So,

the model of 8.5 lakh cells was selected for the rest of the investigation.

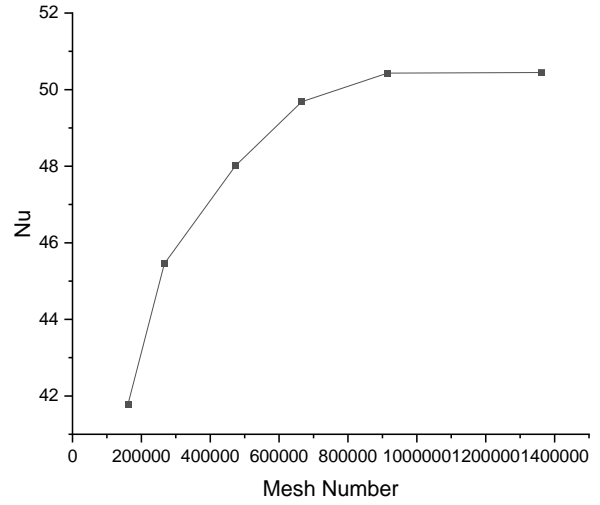

Fig.3 Grid Independency Test

4. Results and Discussions

From the below contours, it is seen that for both hot and cold fluids, the temperature difference between the inlet and outlet reduces with the increase of the Reynolds number. It's because when velocity increases, fluid gets less time to exchange heat. It is also seen in two yoke-like regions near the outlet. These are two low-pressure regions. The pressure in these regions decreases with the increase of the Reynolds number. At a very high Reynolds number, this pressure goes lower than the outlet pressure. As a result, reverse flow occurs. Among those contours, significant color variation is seen below Re 3000.

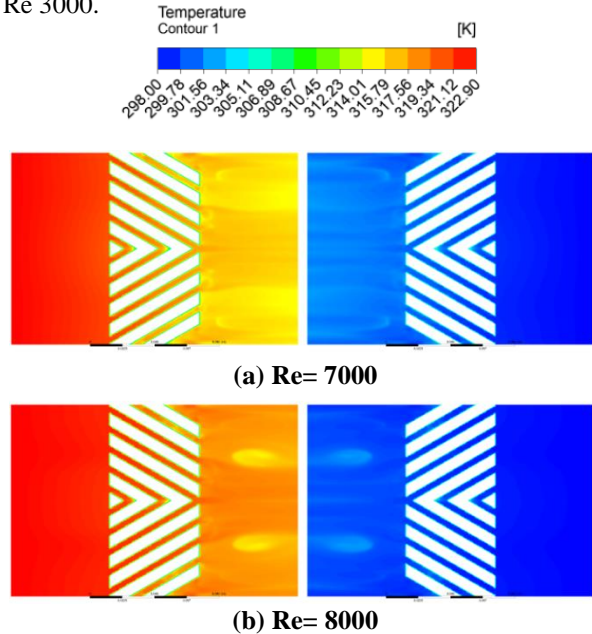

Fig.4: Temperature contour For Reynolds number (a) 7000, (b) 8000 in Hot Outlet and Cold Outlet

Temperature change is significant in low Reynolds numbers. The outlet temperature of the hot fluid

increases with the increase of the Reynolds number and this can be observed in Fig.5

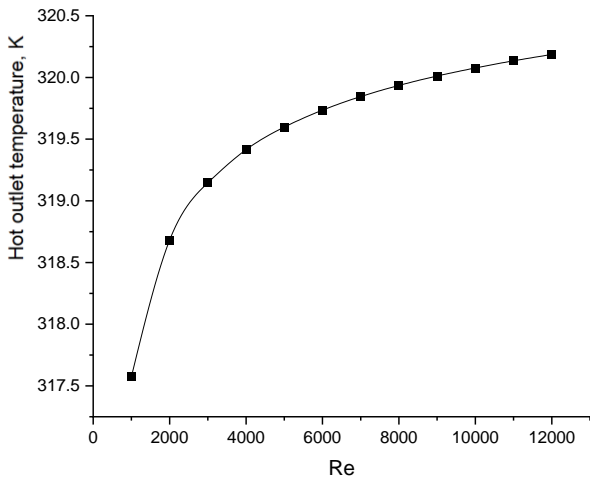

Fig.5: Hot outlet temperature vs Reynolds number

On the other hand, the outlet temperature of the cold fluid decreases with the increase of the Reynolds number, which is seen in Fig.6. But in both cases, the increment and the decrement rate decrease with the increment of the Reynolds number. The temperature of the outlets remains nearly unchanged in high Reynolds number. For the hot outlet, a temperature difference of 5.427K is seen with a Reynolds number 1000. This difference decreases to 4.317K for Reynolds number 2000. However, for Reynolds numbers 10000, 11000, and 12000, these differences are 2.923K, 2.865K, and 2.814K. The same scenario is also seen in Cold outlets. For Reynolds number 1000, the temperature difference of 2.713K is seen. This difference decreases to 2.158K for Reynolds number 2000. Nevertheless, for Reynolds numbers 10000, 11000, and 12000, these differences are 1.461K, 1.432K, and 1.407K. So, a very high Reynolds number does not give a significant result.

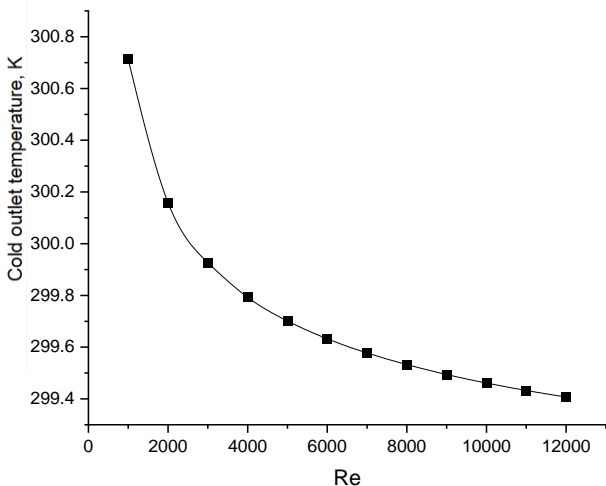

Fig.6: Cold outlet temperature vs Reynolds number

From Fig.7, the change of surface heat transfer coefficient along with the change of Reynolds number is

seen. The surface heat transfer coefficient has a linear relation with the Reynolds number. For a meager Reynolds number of 1000, the surface heat transfer coefficient is $2121.22 \text{ Wm}^{-2}\text{K}^{-1}$. This value increases to $12541.73 \text{ Wm}^{-2}\text{K}^{-1}$ for Reynolds number 12000.

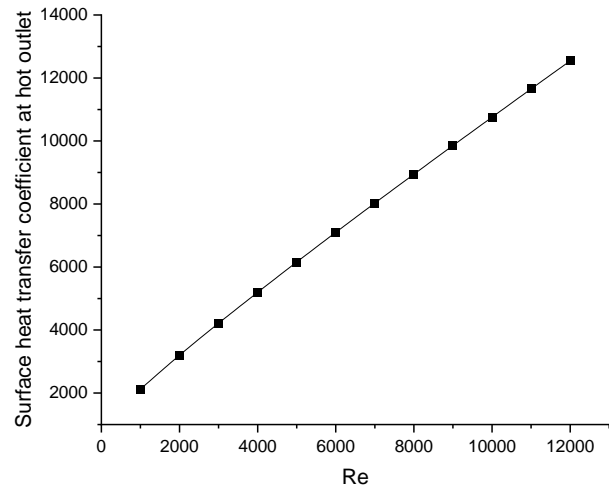

Fig.7: Change of heat transfer coefficient (h) of hot outlet along with Reynolds number

The surface Nusselt number at the outlet also has a linear relationship with the Reynolds number. A Surface Nusselt number of 20.18 is seen for Reynolds number 1000. Furthermore, for A Reynolds number of 2000, the value changes to 122.16. This value changes with the mass flow rate actually.

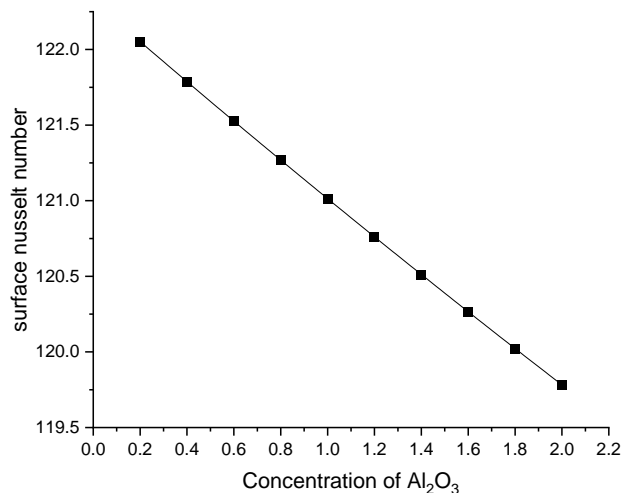

Fig.8: Change of Nusselt number, Nu of hot outlet with Reynolds number

Contours of hot and cold fluid for different concentrations of Al_3O_2 nanofluid particles are shown in Fig.9. Here Reynolds number was fixed for both hot and cold fluid for every concentration of nanoparticle in a nanofluid. Temperature difference increased gradually with the increased concentration.

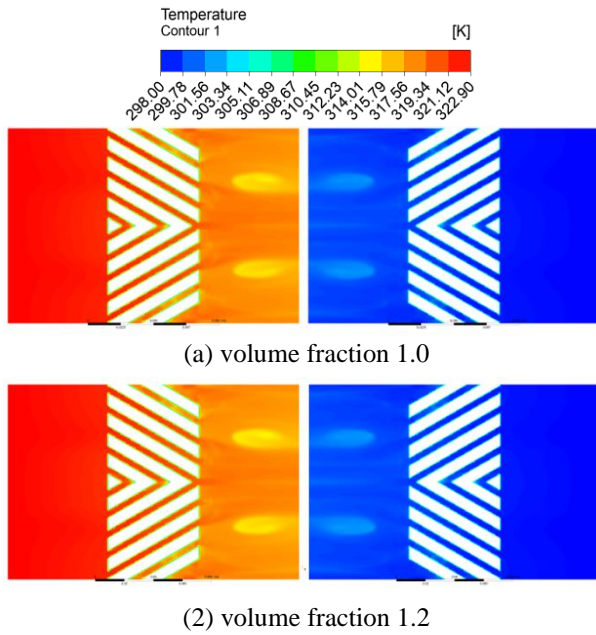

Fig.9: Temperature contour for Reynolds number 10000 for volume fraction (1)1.0 and (2) 1.2 in Hot Outlet and Cold Outlet

Fig.10 and Fig.11 represent the changes in hot and cold outlet temperature with the change in concentration of nanofluid for a fixed Reynolds number in hot and cold inlets. Here, for inlets, the Reynolds number is fixed at 10000. Nanofluid concentration has been taken (0.2-2.0) for calculation. Temperature change with the concentration of nanofluid shows a linear relationship. For a 0.2% volume fraction of nanoparticle, the hot outlet temperature is found to be 319.85K and for the cold outlet, the temperature value is 299.48K. For a high concentration of 2% volume. Fraction of nanoparticles, hot outlet temperature is found to be 319.74K and cold outlet temperature is found to be 299.53K.

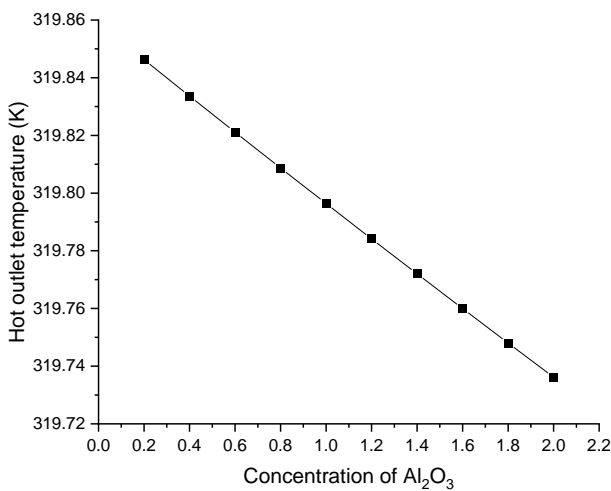

Fig.10. Hot outlet temperature vs Volume fraction

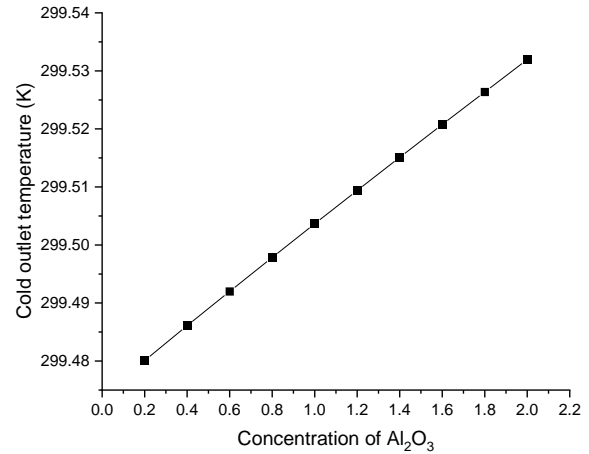

Fig.11. Cold outlet temperature vs Volume fraction

The relation between surface Nusselt number and concentration of nanofluid in Fig.12 shows that the surface Nusselt decreases with increase in concentration. With the increased volume fraction of Al₂O₃ the Cp of the fluid increases so the conduction heat transfer increases. But convection heat transfer remains constant as the Reynolds number is taken constant for the conditions. So Nusselt number decreases gradually. Surface Nusselt number is found 122.16 for volume fraction 0.2. It reduces to 119.78 for volume fraction 2.0

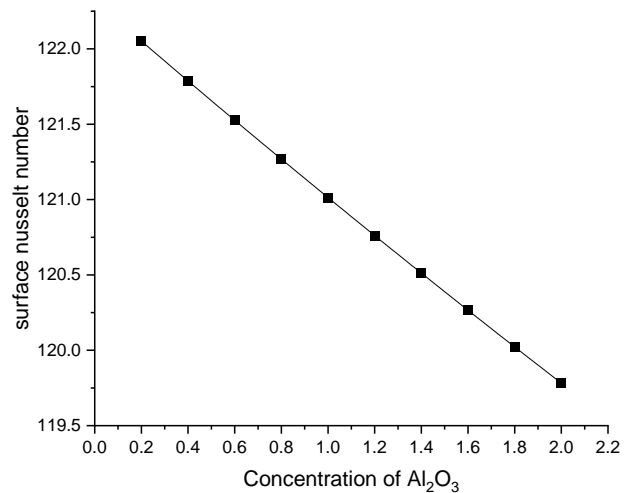

Fig.12: Change of Surface Nusselt number, Nu for different volume fraction in hot and cold

Surface heat transfer coefficient increases with the increase in volume fraction of nanoparticle in nanofluid in Fig.13. This is because the conduction heat transfer increases with increased volume fraction of nanoparticle. So, total heat transfer increases. Heat transfer coefficient for 0.2% volume fraction of nanofluid is 12605.46 W/m²K. A heat transfer coefficient of 12785.68 W/m²K is found for volume fraction 1.0. This value increases to 13017.43 W/m²K for a volume fraction of 2.0.

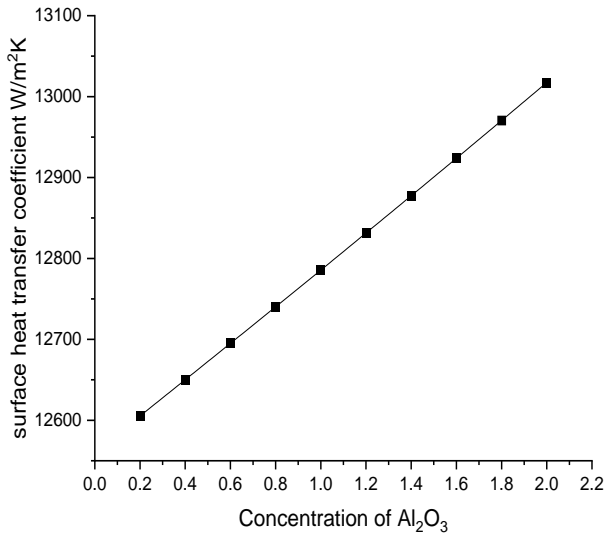

Fig.13: Change of heat transfer coefficient, h for different volume fraction in hot and cold

5. Conclusions

The Nusselt number and average heat transfer coefficient of hot fluid outlets increase with the increase of the Reynolds number in both fluids simultaneously. The increment is linear for both. When the volume fraction of nanoparticles increases in nanofluid the average heat transfer coefficient also increases linearly. It shows an opposite reaction to the Nusselt Number as it decreases linearly with increasing volume fraction of nanoparticles in nanofluid. The heat transfer coefficient increases by about 2.27% for the volume fraction of nanoparticles from 0.2% to 2.0% whereas for the Nusselt number it decreases by about 1.86%.

6. References

- [1] A. Jokar and S. P. O'Halloran, "Heat transfer and fluid flow analysis of nanofluids in corrugated plate heat exchangers using computational fluid dynamics simulation," *Journal of Thermal Science and Engineering Applications*, vol. 5, no. 1, p. 011002, 2013.
- [2] M. Pantzali, A. Kanaris, K. Antoniadis, A. Mouza, and S. Paras, "Effect of nanofluids on the performance of a miniature plate heat exchanger with modulated surface," *International Journal of Heat and Fluid Flow*, vol. 30, no. 4, pp. 691-699, 2009.
- [3] M. Pantzali, A. Mouza, and S. Paras, "Investigating the efficacy of nanofluids as coolants in plate heat exchangers (PHE)," *Chemical Engineering Science*, vol. 64, no. 14, pp. 3290-3300, 2009.
- [4] A. K. Santra, S. Sen, and N. Chakraborty, "Study of heat transfer due to laminar flow of copper-water nanofluid through two isothermally heated parallel plates," *International journal of thermal sciences*, vol. 48, no. 2, pp. 391-400, 2009.
- [5] K. S. Hwang, S. P. Jang, and S. U. Choi, "Flow and convective heat transfer characteristics of water-based Al₂O₃ nanofluids in fully developed laminar flow regime," *International journal of heat and mass transfer*, vol. 52, no. 1-2, pp. 193-199, 2009.
- [6] S. E. B. Maiga, C. T. Nguyen, N. Galanis, and G. Roy, "Heat transfer behaviours of nanofluids in a uniformly heated tube," *Superlattices and Microstructures*, vol. 35, no. 3-6, pp. 543-557, 2004.
- [7] R. K. Ajeel *et al.*, "Turbulent convective heat transfer of silica oxide nanofluid through corrugated channels: An experimental and numerical study," *International Journal of Heat and Mass Transfer*, vol. 145, p. 118806, 2019.
- [8] K. Wongcharee and S. Eiamsa-ard, "Heat transfer enhancement by using CuO/water nanofluid in corrugated tube equipped with twisted tape," *International Communications in Heat and Mass Transfer*, vol. 39, no. 2, pp. 251-257, 2012.
- [9] M. Lazarevikj, R. V. Filkoski, and Z. Markov, "CFD analysis of heat transfer and fluid flow in plate heat exchanger with nanofluid," in *Conference Paper, July*, 2018.
- [10] Y. He, Y. Men, Y. Zhao, H. Lu, and Y. Ding, "Numerical investigation into the convective heat transfer of TiO₂ nanofluids flowing through a straight tube under the laminar flow conditions," *Applied Thermal Engineering*, vol. 29, no. 10, pp. 1965-1972, 2009.
- [11] A. D. Sommers and K. L. Yerkes, "Experimental investigation into the convective heat transfer and system-level effects of Al₂O₃-propanol nanofluid," *Journal of Nanoparticle Research*, vol. 12, no. 3, pp. 1003-1014, 2010.
- [12] B. Saleh and L. S. Sundar, "Experimental study on heat transfer, friction factor, entropy and exergy efficiency analyses of a corrugated plate heat exchanger using Ni/water nanofluids," *International Journal of Thermal Sciences*, vol. 165, p. 106935, 2021.
- [13] Q. Hu, X. Qu, W. Peng, and J. Wang, "Experimental and numerical investigation of turbulent heat transfer enhancement of an intermediate heat exchanger using corrugated tubes," *International Journal of Heat and Mass Transfer*, vol. 185, p. 122385, 2022.
- [14] M. Zaboli, S. Saedodin, S. S. Mousavi Ajarostaghi, and M. Nourbakhsh, "Numerical evaluation of the heat transfer in a shell and corrugated coil tube heat exchanger with three various water - based nanofluids," *Heat Transfer*, vol. 50, no. 6, pp. 6043-6067, 2021.
- [15] F. R. Menter, "Two-equation eddy-viscosity turbulence models for engineering applications," *AIAA journal*, vol. 32, no. 8, pp. 1598-1605, 1994.